

Fourier optics – 2f Arrangement 2.6.11-00

What you can learn about ...

- Fourier transform
- Lenses
- Fraunhofer diffraction
- Index of refraction
- Huygens' principle

Principle:

The electric field distribution of light in a specific plane (object plane) is Fourier transformed into the 2f configuration.



What you need:

Optical base plate with rubberfeet	08700.00	1
He/Ne Laser, 5mW with holder	08701.00	1
Power supply for laser head 5 mW	08702.93	1
Adjusting support 35 x 35 mm	08711.00	2
Surface mirror 30 x 30 mm	08711.01	2
Magnetic foot for optical base plate	08710.00	7
Holder for diaphragm/ beam plitter	08719.00	1
Lens, mounted, $f = +150$ mm	08022.01	1
Lens, mounted, $f = +100$ mm	08021.01	1
Lens holder for optical base plate	08723.00	2
Screen, white, 150 x 150 mm	09826.00	1
Diffraction grating, 50 lines/mm	08543.00	1
Screen with diffracting elements	08577.02	1
Achromatic objective 20 x N.A.0.4	62174.20	1
Sliding device, horizontal	08713.00	1
XY-shifting device	08714.00	2
Adapter ring device	08714.01	1
Pin hole 30 micron	08743.00	1
Rule, plastic, 200 mm	09937.01	1

Complete Equipment Set, Manual on CD-ROM included
 Fourier optics– 2f Arrangement P2261100

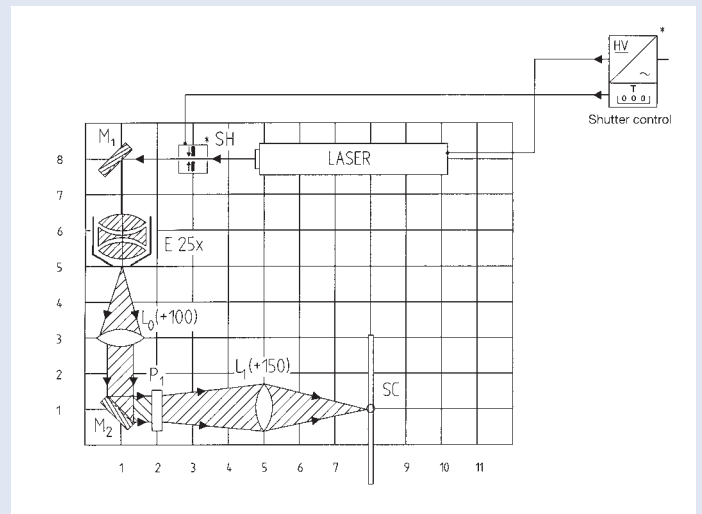

Experimental set-up for the fundamental principles of Fourier optic (2f set-up). *only required for the 5 mW laser!

Tasks:

Investigation of the Fourier transform by a convex lens for different diffraction objects in a 2f set-up.